



US 20200044002A1

(19) **United States**

(12) **Patent Application Publication**  
JUN

(10) **Pub. No.: US 2020/0044002 A1**

(43) **Pub. Date: Feb. 6, 2020**

(54) **DISPLAY DEVICE**

27/3262 (2013.01); *H01L 51/5271* (2013.01);  
*H01L 51/5218* (2013.01)

(71) Applicant: **LG Display Co., Ltd.**, Seoul (KR)

(72) Inventor: **Changhwa JUN**, Paju-si (KR)

(57)

**ABSTRACT**

(73) Assignee: **LG Display Co., Ltd.**, Seoul (KR)

(21) Appl. No.: **16/522,025**

(22) Filed: **Jul. 25, 2019**

(30) **Foreign Application Priority Data**

Jul. 31, 2018 (KR) ..... 10-2018-0088955

**Publication Classification**

(51) **Int. Cl.**

*H01L 27/32* (2006.01)

*H01L 51/52* (2006.01)

(52) **U.S. Cl.**

CPC ..... *H01L 27/3258* (2013.01); *H01L 27/3246*  
(2013.01); *H01L 27/1248* (2013.01); *H01L*

A display device includes a substrate provided with a plurality of subpixel areas, a circuit element layer provided on the substrate and provided with a transistor for each subpixel area, an insulating layer provided on the circuit element layer and provided with a recessed portion formed to overlap the transistor, a reflective electrode provided on the insulating layer and provided in the recessed portion, a first electrode provided on the reflective electrode while being overlapped with the recessed portion, an organic light emitting layer provided on the first electrode, a bank provided between the subpixel areas while covering an end of the first electrode, and a second electrode provided on the organic light emitting layer, wherein the recessed portion, the reflective electrode and the first electrode may be provided with N stages, wherein N is an integer greater than 1, whereby light efficiency may be improved.

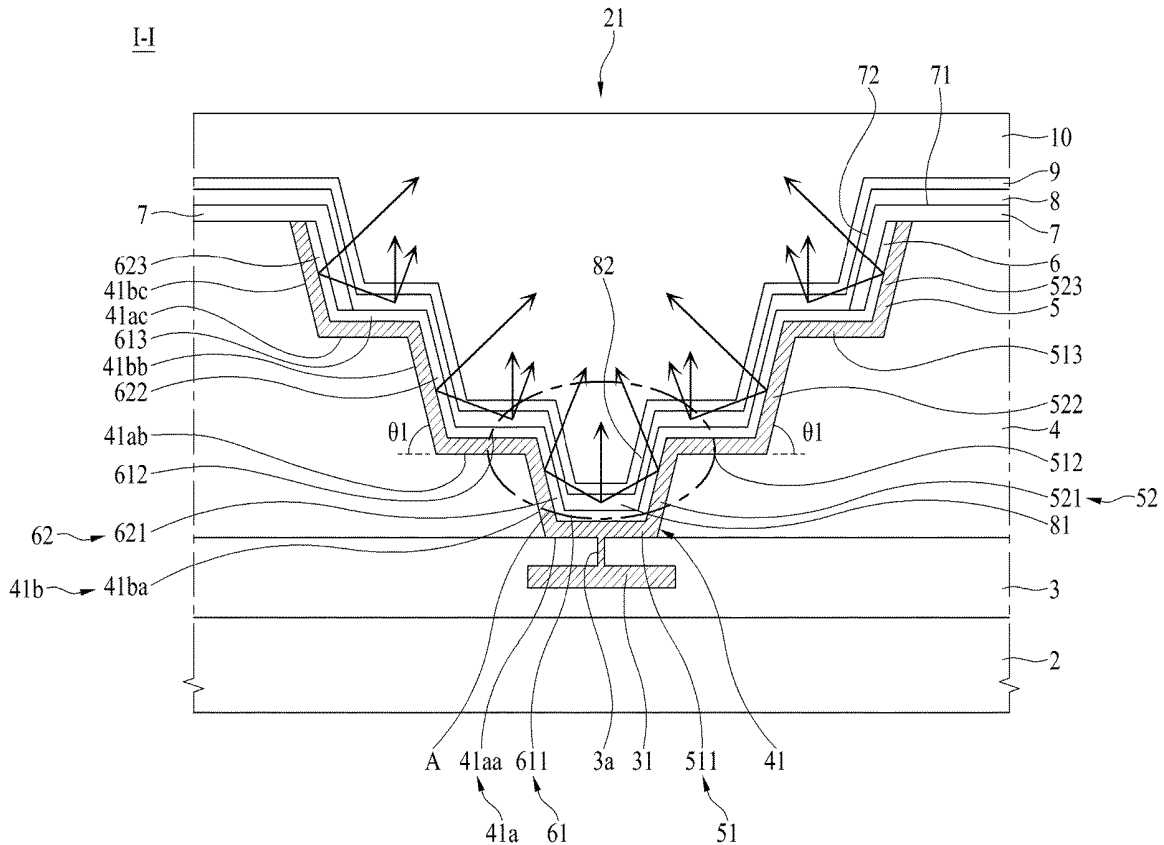

FIG. 1

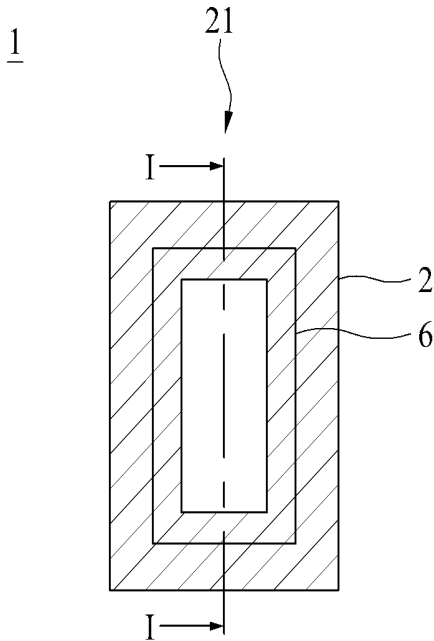

FIG. 2A

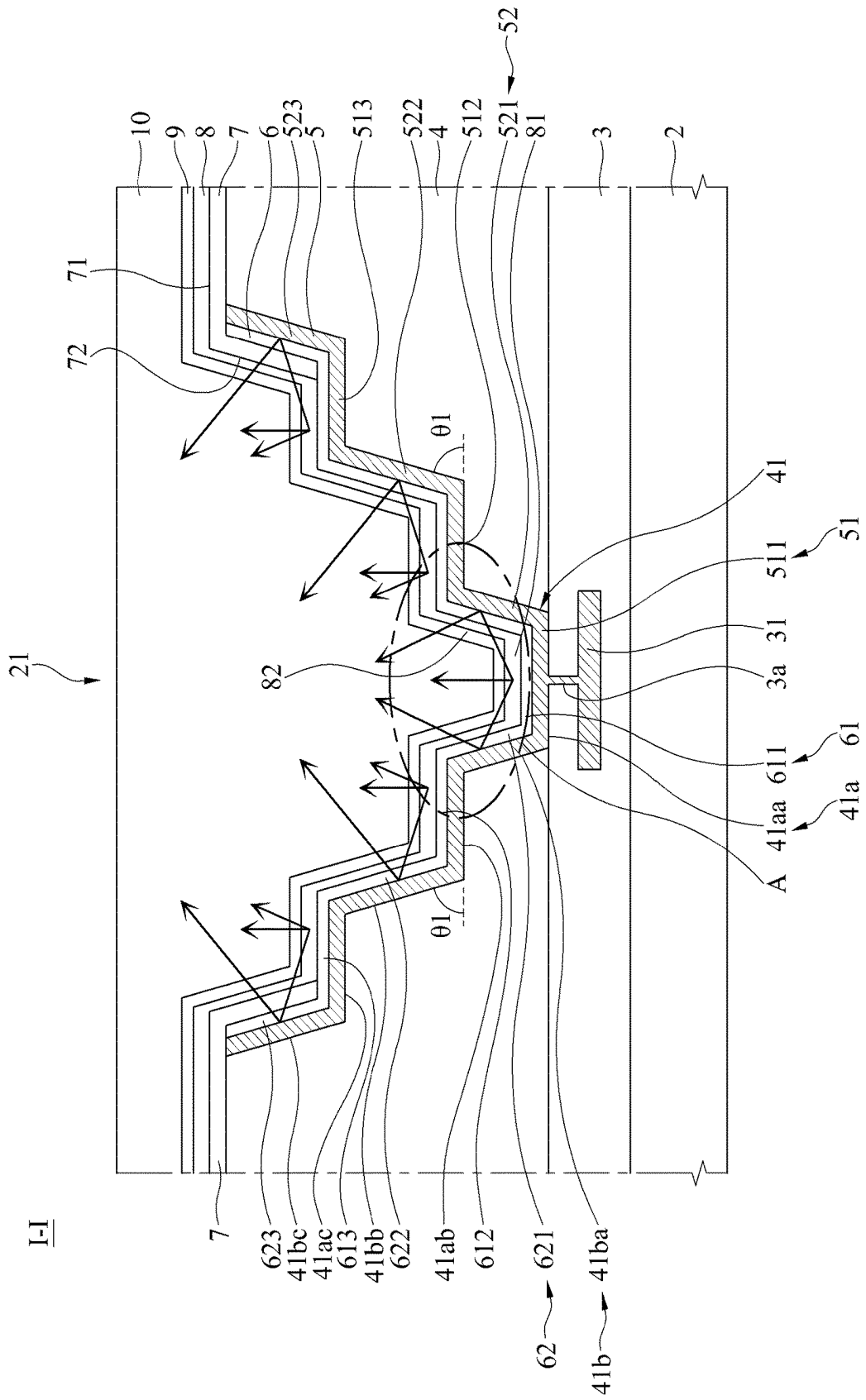

FIG. 2B

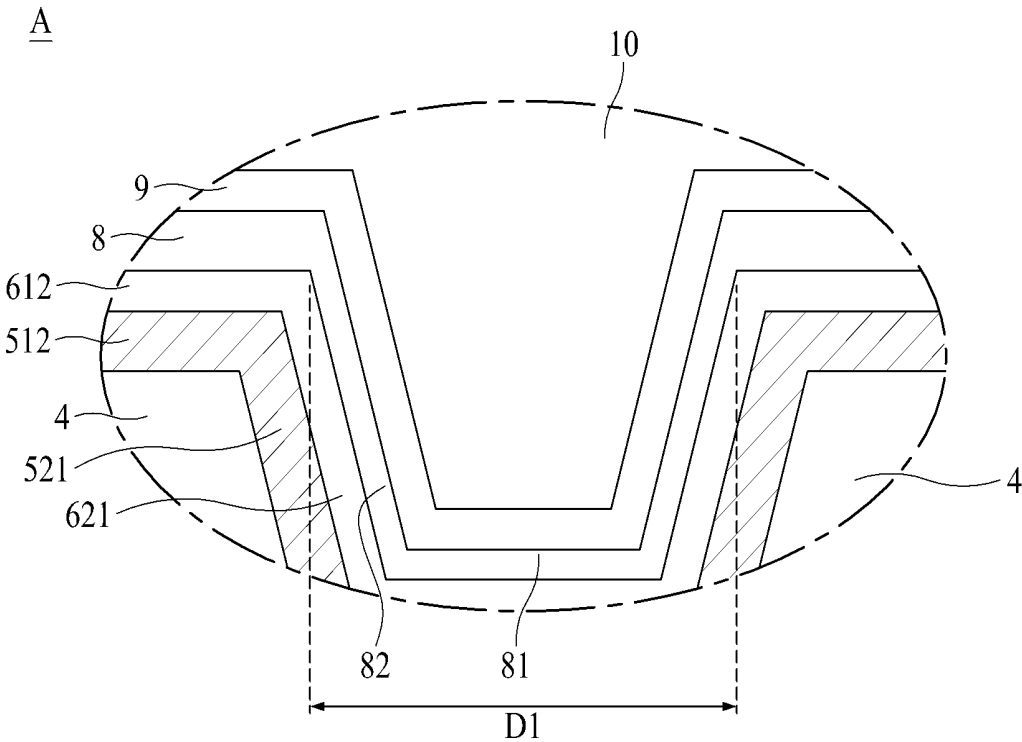

FIG. 3A

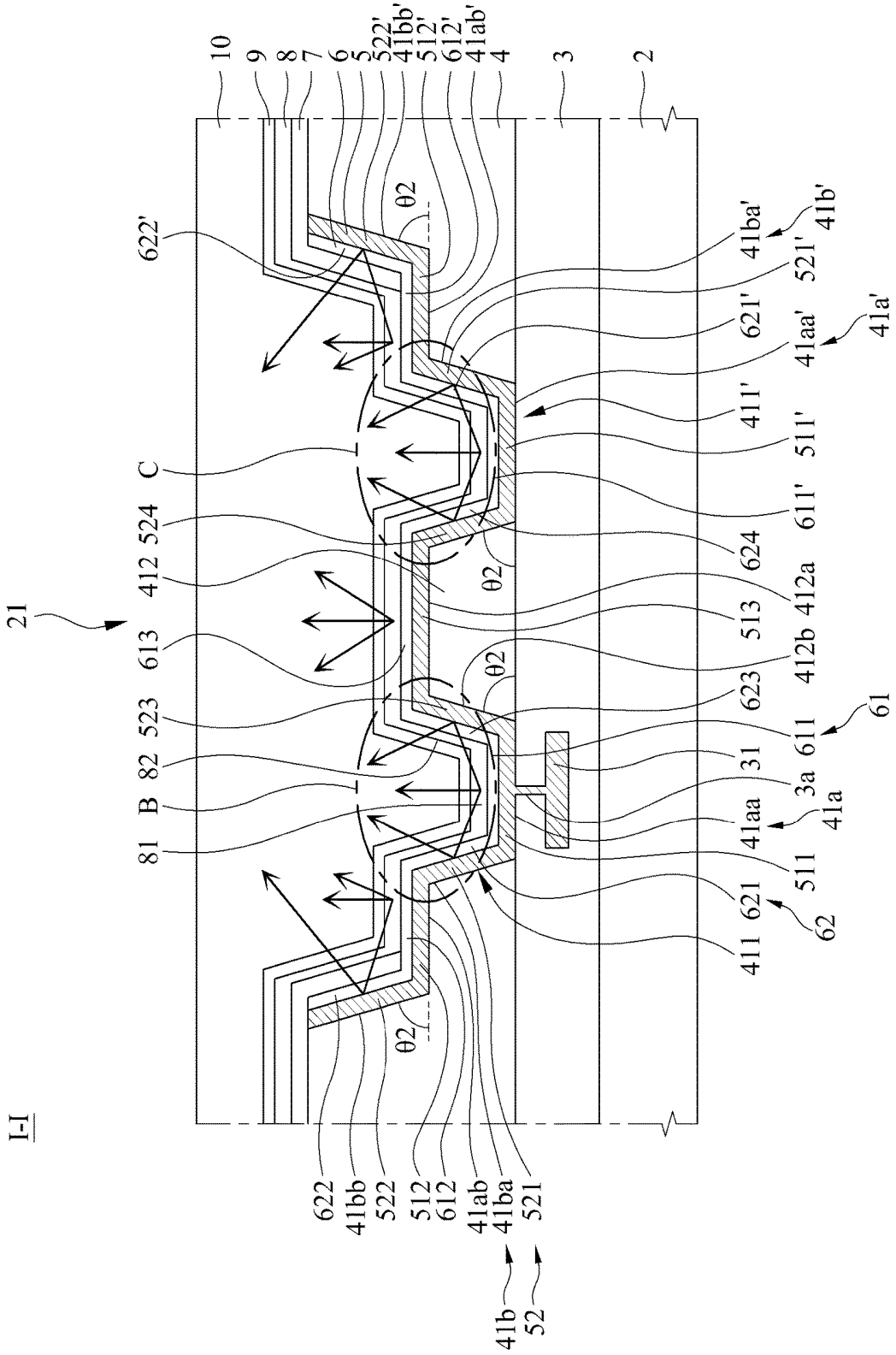

FIG. 3B

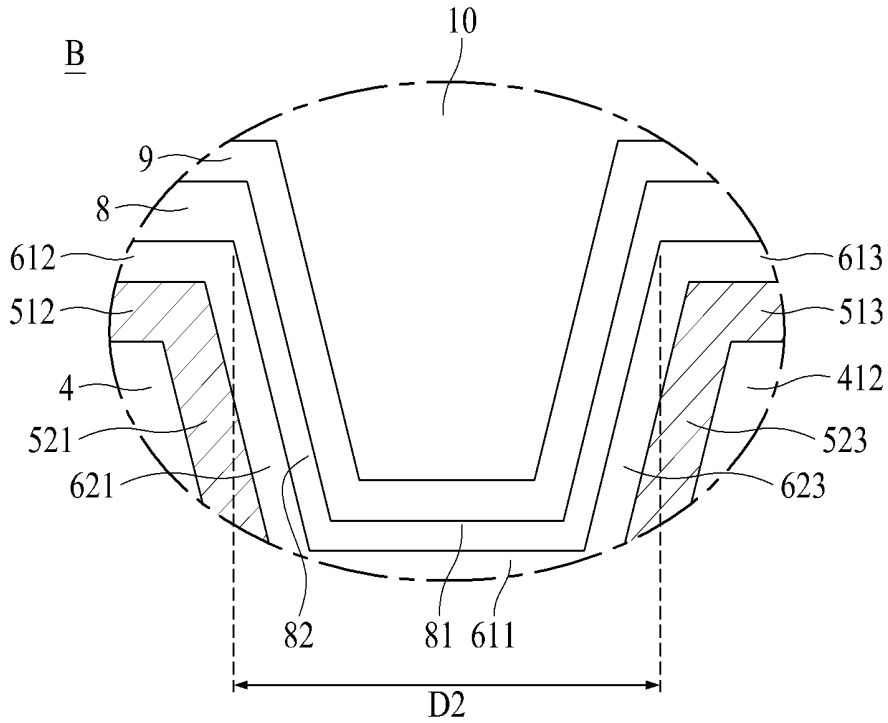

FIG. 3C

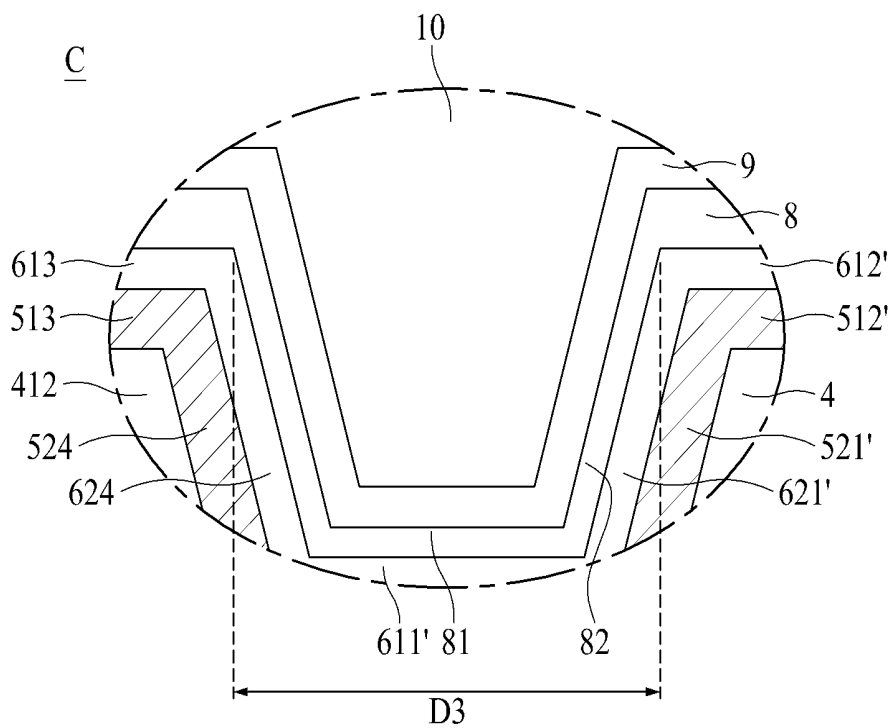



FIG. 5A

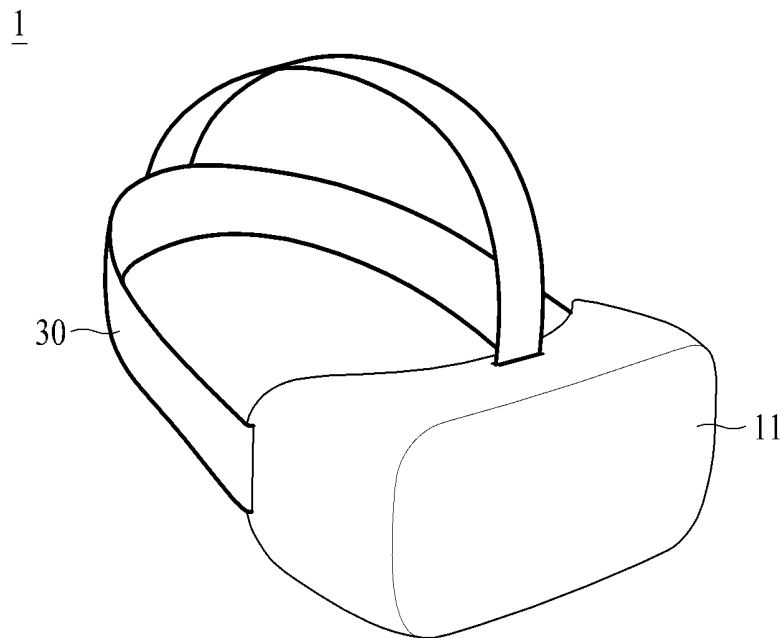

FIG. 5B

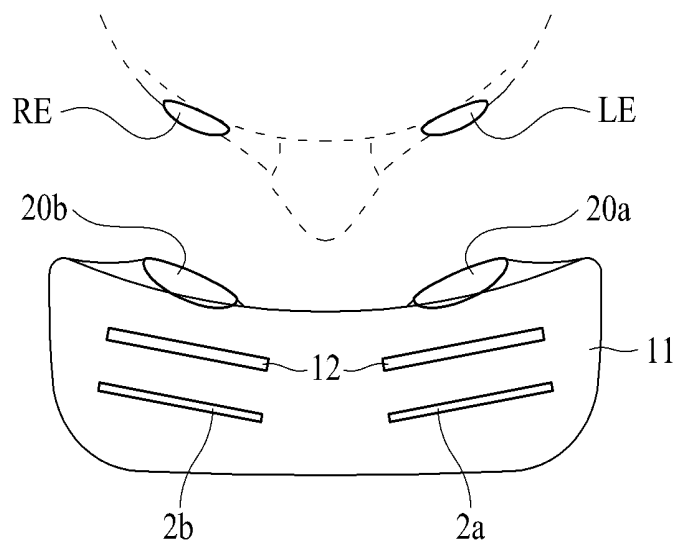
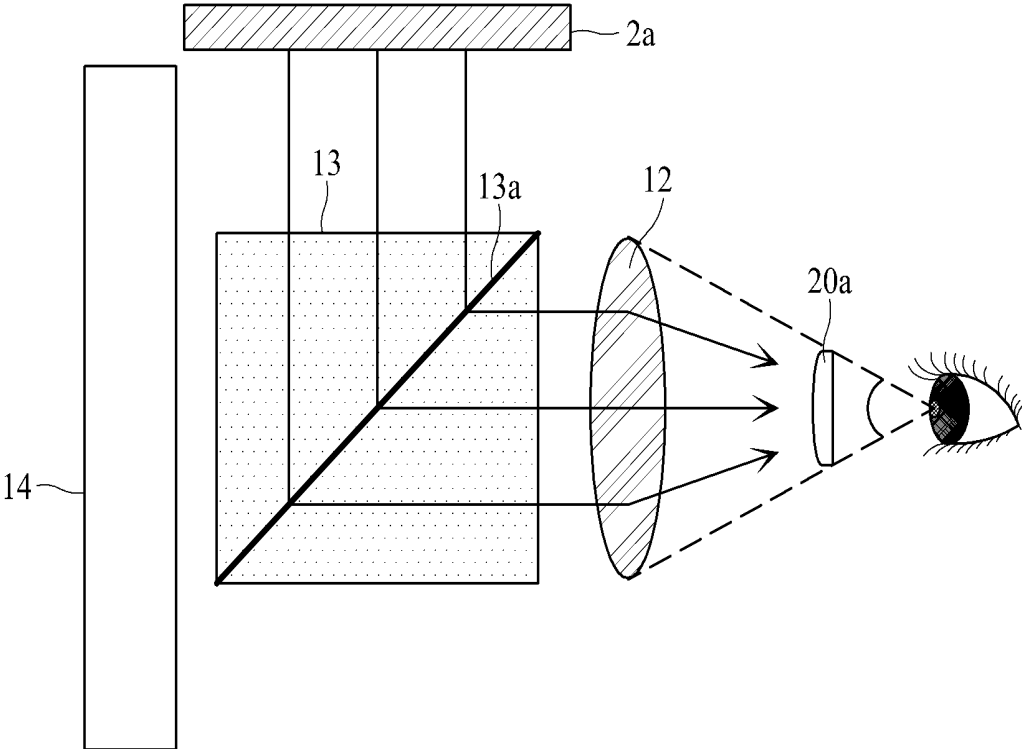

FIG. 5C



## DISPLAY DEVICE

### BACKGROUND

#### Technical Field

[0001] The present disclosure relates to a display device displaying an image.

#### Description of the Related Art

[0002] With the advancement of the information age, the demand for a display device for displaying an image has increased with various forms. Therefore, various types of display devices such as a liquid crystal display (LCD) device, a plasma display panel (PDP) display device, and an organic light emitting display (OLED) device have been used.

[0003] Among the display devices, the organic light emitting display device is a self-light emitting device, and has advantages in that a viewing angle and a contrast ratio are more excellent than those of the liquid crystal display (LCD) device. Also, since the organic light emitting display device does not require a separate backlight, it is advantageous that the organic light emitting display device is able to be thin and lightweight and has low power consumption. Furthermore, the organic light emitting display device has advantages in that it may be driven at a low direct current voltage, has a fast response speed, and especially has a low manufacturing cost.

[0004] Recently, a head mounted display (HMD) including such an organic light emitting display device has been developed. The head mounted display is a glasses type monitor device of virtual reality (VR), which forms a focal point on a close distance in front of eyes of a user who wears the HMD in glasses or helmet type.

[0005] On the other hand, the organic light emitting display device has a problem in improving light efficiency because light is emitted from a light emitting area of which size is restrictive. Such a problem occurs more seriously in case of a head mounted display including an organic light emitting display device. Therefore, studies for a head mounted display with ultra-high resolution that can improve light efficiency have been actively ongoing.

### SUMMARY

[0006] Accordingly, embodiments of the present disclosure are directed to a display device that substantially obviates one or more of the problems due to limitations and disadvantages of the related art.

[0007] An aspect of the present disclosure is to provide a display device that can improve light efficiency.

[0008] Additional features and aspects will be set forth in the description that follows, and in part will be apparent from the description, or may be learned by practice of the inventive concepts provided herein. Other features and aspects of the inventive concepts may be realized and attained by the structure particularly pointed out in the written description, or derivable therefrom, and the claims hereof as well as the appended drawings.

[0009] To achieve these and other aspects of the inventive concepts, as embodied and broadly described, a display device comprises a substrate provided with a plurality of subpixel areas, a circuit element layer provided on the substrate and provided with a transistor for each subpixel

area, an insulating layer provided on the circuit element layer and provided with a recessed portion formed to overlap the transistor, a reflective electrode provided on the insulating layer and provided in the recessed portion, a first electrode provided on the reflective electrode while being overlapped with the recessed portion, an organic light emitting layer provided on the first electrode, a bank provided between the subpixel areas while covering an end of the first electrode, and a second electrode provided on the organic light emitting layer, wherein the recessed portion, the reflective electrode and the first electrode may be provided with N stages, wherein N is an integer greater than 1.

[0010] In the display device according to the present disclosure, as a contact hole for connecting the first electrode with the transistor may be provided with multiple stages and used as a light emitting area to improve light efficiency.

[0011] It is to be understood that both the foregoing general description and the following detailed description are exemplary and explanatory and are intended to provide further explanation of the inventive concepts as claimed.

### BRIEF DESCRIPTION OF THE DRAWINGS

[0012] The accompanying drawings, which are included to provide a further understanding of the disclosure and are incorporated in and constitute a part of this application, illustrate embodiments of the disclosure and together with the description serve to explain various principles. In the drawings:

[0013] FIG. 1 is a brief plane view illustrating a display device according to one embodiment of the present disclosure;

[0014] FIG. 2A is a brief cross-sectional view taken along line I-I shown in FIG. 1;

[0015] FIG. 2B is a brief enlarged view illustrating a part A shown in FIG. 2A;

[0016] FIG. 3A is a brief cross-sectional view illustrating a display device according to the second embodiment of the present disclosure;

[0017] FIG. 3B is a brief enlarged view illustrating a part B shown in FIG. 3A;

[0018] FIG. 3C is a brief enlarged view illustrating a part C shown in FIG. 3A;

[0019] FIG. 4 is a brief cross-sectional view illustrating a display device according to the third embodiment of the present disclosure; and

[0020] FIGS. 5A to 5C are views illustrating a display device according to another embodiment of the present disclosure, and relate to a head-mounted display (HMD) device.

### DETAILED DESCRIPTION

[0021] Advantages and features of the present disclosure, and implementation methods thereof will be clarified through following embodiments described with reference to the accompanying drawings. The present disclosure may, however, be embodied in different forms and should not be construed as limited to the embodiments set forth herein. Rather, these embodiments are provided so that this disclosure will be thorough and complete, and will fully convey the scope of the present disclosure to those skilled in the art. Further, the present disclosure is only defined by scopes of claims.

**[0022]** A shape, a size, a ratio, an angle, and a number disclosed in the drawings for describing embodiments of the present disclosure are merely an example, and thus, the present disclosure is not limited to the illustrated details. Like reference numerals refer to like elements throughout the specification. In the following description, when the detailed description of the relevant known function or configuration is determined to unnecessarily obscure the important point of the present disclosure, the detailed description will be omitted. In a case where ‘comprise’, ‘have’, and ‘include’ described in the present specification are used, another part may be added unless ‘only~’ is used. The terms of a singular form may include plural forms unless referred to the contrary.

**[0023]** In construing an element, the element is construed as including an error range although there is no explicit description.

**[0024]** In describing a position relationship, for example, when the position relationship is described as ‘upon~’, ‘above~’, ‘below~’, and ‘next to~’, one or more portions may be arranged between two other portions unless ‘just’ or ‘direct’ is used.

**[0025]** It will be understood that, although the terms “first”, “second”, etc. may be used herein to describe various elements, these elements should not be limited by these terms. These terms are only used to partition one element from another. For example, a first element could be termed a second element, and, similarly, a second element could be termed a first element, without departing from the scope of the present disclosure.

**[0026]** In describing elements of the present disclosure, the terms “first”, “second”, etc. may be used. These terms are intended to identify the corresponding elements from the other elements, and basis, order, or number of the corresponding elements are not limited by these terms. The expression that an element is “connected” or “coupled” to another element should be understood that the element may directly be connected or coupled to another element but may directly be connected or coupled to another element unless specially mentioned, or a third element may be interposed between the corresponding elements.

**[0027]** Features of various embodiments of the present disclosure may be partially or overall coupled to or combined with each other, and may be variously inter-operated with each other and driven technically as those skilled in the art can sufficiently understand. The embodiments of the present disclosure may be carried out independently from each other, or may be carried out together in co-dependent relationship.

**[0028]** Hereinafter, the embodiments of the display device according to the present disclosure will be described in detail with reference to the accompanying drawings. Wherever possible, the same reference numbers will be used throughout the drawings to refer to the same or like parts.

**[0029]** FIG. 1 is a brief plane view illustrating a display device according to one embodiment of the present disclosure, FIG. 2A is a brief cross-sectional view taken along line I-I shown in FIG. 1, and FIG. 2B is a brief enlarged view illustrating a part A shown in FIG. 2A.

**[0030]** With reference to FIGS. 1 to 2B, the display device 1 according to one embodiment of the present disclosure comprises a substrate 2, a circuit element layer 3, an insulating layer 4, a reflective electrode 5, a first electrode 6,

a bank 7, an organic light emitting layer 8, a second electrode 9, and an encapsulation layer 10.

**[0031]** The insulating layer 4 may include a recessed portion 41, and the recessed portion 41, the reflective electrode 5 and the first electrode 6 may be provided with N stages (N is an integer greater than 1). The reason why the recessed portion 41, the reflective electrode 5 and the first electrode 6 are provided with N stages, that is, multiple stages will be described with description of a light path at each stage after a structure of the display device 1 according to one embodiment of the present disclosure is described.

**[0032]** The substrate 2 may be a semiconductor substrate such as a plastic film, a glass substrate, or silicon.

**[0033]** The substrate 2 may include a plurality of subpixel areas. In the present disclosure, one of the plurality of subpixel areas, for example, a first subpixel area 21 will be described as an example. The plurality of subpixel areas including the first subpixel area 21 may be arranged to be adjacent to one another.

**[0034]** The first subpixel area 21 may emit light of various colors including white. The first subpixel area 21 may include an organic light emitting diode that includes a reflective electrode 5, a first electrode 6, an organic light emitting layer 8, and a second electrode 9.

**[0035]** The circuit element layer 3 is arranged on one surface of the substrate 2. The circuit element layer 3 may include a plurality of transistors, gate lines, data lines, and subpixels. The subpixels are provided in an area defined by a crossing structure of the gate lines and data lines. The circuit element layer 3 may include transistors per the plurality of subpixel areas. For example, the circuit element layer 3 may include a first transistor 31.

**[0036]** The first transistor 31 is arranged on the first subpixel area 21 in the circuit element layer 3. The first transistor 31 according to one example may be connected to a first sub electrode 61 through a first reflective electrode 51 arranged on the first subpixel area 21 to apply a driving voltage for emitting light of a color corresponding to the first subpixel area 21.

**[0037]** The first subpixel area 21 according to one example provides an organic light emitting diode with a predetermined current in accordance with a data voltage of a data line when a gate signal from a gate line is input thereto using the first transistor 31. For this reason, the organic light emitting diode of the first subpixel area 21 may emit light with predetermined brightness in accordance with a predetermined current.

**[0038]** The insulating layer 4 may be provided on the substrate 2. In more detail, the insulating layer 4 may be arranged on the circuit element layer 3 arranged on the substrate 2.

**[0039]** The insulating layer 4 may include a recessed portion 41 provided on the first subpixel area 21. The recessed portion 41, as shown in FIG. 2A, may be formed to overlap the first transistor 31. The recessed portion 41 may be formed by patterning the insulating layer 4 arranged on the first subpixel area 21 using a lift-off or dry etching process. The recessed portion 41 may be formed on the first subpixel area 21 in a recessed shape toward the substrate 2 from the organic light emitting layer 7.

**[0040]** The recessed portion 41 may be formed in a recessed shape of the insulating layer 4 so that the reflective electrode 5 arranged on the recessed portion 41 may reflect light toward the first subpixel area 21. The insulating layer

4 having the recessed portion 41 is provided separately from the circuit element layer 3 but is not limited to this example. The recessed portion 41 may be formed by patterning the circuit element layer 3 without the insulating layer 4. In this case, since the overall thickness of the display device 1 according to one embodiment of the present disclosure may be reduced, the display device 1 may be embodied in a compact size and embodied to enhance wearability and convenience of movement due to a reduced weight according to the reduced thickness.

[0041] The recessed portion 41 may be formed on the insulating layer 4 through various patterning methods without limitation to the patterning method such as lift-off or dry etching. The insulating layer 4 including the recessed portion 41 may be formed on the circuit element layer 3 through a deposition method.

[0042] The recessed portion 41 may be provided with N stages (N is an integer greater than 1). For example, the recessed portion 41 may be provided in two stages or more, and may be provided with three stages as shown in FIG. 2A. Among first, second and third stages, the first stage may be arranged to be closest to the substrate 2.

[0043] The recessed portion 41 may be provided with three stages or more by a process of one time using a half tone mask. The same recessed portion as the recessed portion 41 may be provided even in the plurality of subpixel areas adjacent to the first subpixel area 21, and these recessed portions may be formed at the same time.

[0044] The recessed portion 41 may be a contact hole for connecting the reflective electrode 5 or the first electrode 6 to the first transistor 31 which may be provided with multiple stages and used as a light emitting area to improve light efficiency.

[0045] The recessed portion 41 may include a plurality of recessed bottom surfaces 41a parallel with the substrate 2, and a plurality of recessed sides 41b inclined with respect to the substrate 2.

[0046] The plurality of recessed bottom surfaces 41a may include a first stage recessed bottom surface 41aa, a second stage recessed bottom surface 41ab, and a third stage recessed bottom surface 41ac. The plurality of recessed sides 41b may include a first stage recessed side 41ba, a second stage recessed side 41bb, and a third stage recessed side 41bc.

[0047] The first stage recessed bottom surface 41aa may be in contact with the circuit element layer 3. A through hole 3a may be formed in the first stage recessed bottom surface 41aa. The through hole 3a is to connect the reflective electrode 5 arranged on the recessed portion 41 to the first transistor 31 to overlap the first transistor 31, and may be formed to pass through the circuit element layer 3. As shown in FIG. 2A, the plurality of recessed bottom surfaces 41a and the plurality of recessed sides 41b may be provided to be symmetrical with each other based on the through hole 3a.

[0048] The first stage recessed side 41ba may be connected to the first stage recessed bottom surface 41aa. The first stage recessed side 41ba may be provided with a pair of first stage recessed sides 41ba to be connected with both ends of the first stage recessed bottom surfaces 41aa. The first stage recessed side 41ba may form a first angle  $\theta_1$  with respect to the substrate 2, wherein the first angle  $\theta_1$  may range from 20° to 70°. Preferably, the first angle  $\theta_1$  may range from 50° to 55°. In this case, the expression that the first stage recessed side 41ba is provided with a pair of first

stage recessed sides 41ba may mean that two elements are provided in a symmetrical shape.

[0049] The second stage recessed bottom surface 41ab may be provided with a pair of second stage recessed bottom surfaces 41ab and connected to an end of each of the pair of first stage recessed sides 41ba which are not connected to the first stage recessed bottom surface 41aa. The second stage recessed bottom surface 41ab may be arranged on a position higher than the first stage recessed bottom surface 41aa.

[0050] The second stage recessed side 41bb may be provided with a pair of second stage recessed sides 41bb and connected to an end of each of the second stage recessed bottom surfaces 41ab which are not connected to the first stage recessed side 41ba. The second stage recessed side 41bb may form a first angle  $\theta_1$  with respect to the substrate 2 in the same manner as the first stage recessed side 41ba.

[0051] The third stage recessed bottom surface 41ac may be provided with a pair of third stage recessed bottom surfaces 41ac and connected to an end of each of the pair of second stage recessed sides 41bb which are not connected to the second stage recessed bottom surface 41ab. The third stage recessed bottom surface 41ac may be arranged on a position higher than the second stage recessed bottom surface 41ab.

[0052] The third stage recessed side 41bc may be provided with a pair of third stage recessed sides 41bc and connected to an end of each of the pair of third stage recessed bottom surfaces 41ac which are not connected to the second stage recessed side 41bb. The third stage recessed side 41bc may form a first angle  $\theta_1$  with respect to the substrate 2 in the same manner as the second stage recessed side 41bb.

[0053] Therefore, the plurality of recessed bottom surfaces 41a may be arranged at different heights, and the plurality of recessed sides 41b may be spaced apart from one another at different distances. A spaced distance between the pair of recessed sides 41b at each stage may be increased as the recessed sides become far away from the substrate 2. Therefore, in the display device 1 according to one embodiment of the present disclosure, an aperture ratio may be increased.

[0054] Since the pair of recessed bottom surfaces of each stage have the same length and the pair of recessed sides of each stage have the same first angle  $\theta_1$  with respect to the substrate 2, the plurality of recessed bottom surfaces 41a and the plurality of recessed sides 41b may be arranged to be symmetrical with each other based on the through hole 3a.

[0055] The reflective electrode 5 may be provided in the recessed portion 41 on the insulating layer 4. The reflective electrode 5 is to reflect light emitted from the organic light emitting layer 8 of the first subpixel area 21. The reflective electrode 5 may include a reflective material to reflect light. For example, the reflective material may be, but not limited to, a metal, and may be other materials as long as they reflect light.

[0056] Since the reflective electrode 5 is arranged on a place relatively than the organic light emitting layer 8 emitting light, the reflective electrode 5 may reflect light emitted from the organic light emitting layer 8 toward the upper side. In this case, the upper side means a direction where a user can recognize light, for example, it may mean the direction where the encapsulation layer 10 is arranged. Therefore, in a plurality of subpixel areas including the first subpixel 21, light efficiency may be more improved than the case where the reflective electrode 5 is not provided, and a

user may recognize an image of high luminance, that is, a clear image through the enhanced light efficiency.

[0057] The reflective electrode 5 may be provided with multiple stages as the recessed portion 41 is provided with N stages, that is, multiple stages. For example, the reflective electrode 5, as shown in FIG. 2A, may be provided with three stages.

[0058] The reflective electrode 5 may be in contact with the first transistor 31 through the through hole 3a. The reflective electrode 5 may include a plurality of first reflective electrodes 51 parallel with the substrate 2 and a plurality of second reflective electrodes 52 inclined with respect to the substrate 2.

[0059] The plurality of first reflective electrodes 51 may be arranged at different heights based on the substrate 2. In this case, the heights may mean the spaced distance from the substrate 2 toward the encapsulation layer 10.

[0060] The first reflective electrode 51 may be arranged on the first subpixel area 21 to reflect light emitted from the organic light emitting layer 8. In more detail, the first reflective electrode 51 may include a first parallel portion 511 which is in contact with the first stage recessed bottom surface 41aa, a second parallel portion 512 which is in contact with the second stage recessed bottom surface 41ab, and a third parallel portion 513 which is in contact with the third stage recessed bottom surface 41ac. The first parallel portion 511 may be in contact with the first stage recessed bottom surface 41aa and connected to the first transistor 31 through the through hole 3a. The through hole 3a may be arranged at the center of the first parallel portion 511. The second parallel portion 512 and the third parallel portion 513 may be provided in pairs. The first parallel portion 511, the second parallel portion 512 and the third parallel portion 513 may be arranged at their respective heights different from one another.

[0061] The second reflective electrode 52 may be arranged on the first subpixel area 21 to reflect light emitted from the organic light emitting layer 8. In more detail, the second reflective electrode 52 may include a first inclined portion 521 which is in contact with the first stage recessed side 41ba, a second inclined portion 522 which is in contact with the second stage recessed side 41bb, and a third inclined portion 523 which is in contact with the third stage recessed side 41bc. The first inclined portion 521, the second inclined portion 522 and the third inclined portion 523 may be provided in pairs, and may have their respective spaced distances different from each other. The spaced distance of each of the pair of first inclined portions 521, the pair of second inclined portions 522 and the pair of third inclined portions 523 may be increased at a longer distance from the substrate 2.

[0062] The pair of second parallel portions 512 and the pair of the third parallel portions 513 of each stage may be provided to have the same length, and the pair of first inclined portions 521, the pair of second inclined portions 522 and the pair of third inclined portions 523 of each stage may be provided to have the same length and form the first angle  $\theta_1$  with respect to the substrate 2. Therefore, the first parallel portion 511 and the pair of first inclined portions 521, the pair of second parallel portions 512 and the second inclined portion 522, and the pair of third parallel portions 513 and the third inclined portion 523 may be arranged symmetrically based on the through hole 3a.

[0063] As described above, the first angle  $\theta_1$  of the second reflective electrode 52 with respect to the substrate 2 may range from  $20^\circ$  to  $70^\circ$ . Therefore, the second reflective electrode 52 may condense light emitted from the organic light emitting layer 8 while reflecting the light toward the first subpixel area 21. Therefore, a user may recognize an image with improved light efficiency, that is, a clear image. If the first angle  $\theta_1$  is less than  $20^\circ$ , since the second reflective electrode 52 too lies down with respect to the substrate 2, a reflective area where the second reflective electrode 52 reflects light is more widened than the case that the first angle  $\theta_1$  is  $20^\circ$  or more, that is, light is spread, whereby luminance of light may be deteriorated. Therefore, the user may recognize a blurred image.

[0064] If the first angle  $\theta_1$  exceeds  $70^\circ$ , the second reflective electrode 52 is too erect with respect to the substrate 2, whereby the second reflective electrode 52 reflects light toward another subpixel area adjacent to the first subpixel area 21 as compared with the case that the first angle  $\theta_1$  is  $70^\circ$  or less. For this reason, a problem occurs in that a color mixture occurs.

[0065] The expression that the second reflective electrode 52 lies down means that the second reflective electrode 52 is arranged to be close to an angle parallel with the substrate 2, that is,  $0^\circ$  based on the substrate 2. The expression that the second reflective electrode 52 is erect means that the second reflective electrode 52 is arranged to be close to an angle vertical to the substrate 2, that is,  $90^\circ$  based on the substrate 2.

[0066] Therefore, the display device 1 according to one embodiment of the present disclosure may be provided such that the second reflective electrode 52 forms the first angle  $\theta_1$ , whereby a color mixture may be avoided and a clear image may be provided to a user. The first angle  $\theta_1$  may range from  $20^\circ$  to  $70^\circ$ , preferably  $50^\circ$  to  $55^\circ$ .

[0067] The first electrode 6 is provided on the reflective electrode 5 while being overlapped with the recessed portion 41. The first electrode 6 according to one example may be formed to include a metal material of high reflectivity such as a deposited structure (Ti/Al/Ti) of aluminum and titanium, a deposited structure (ITO/Al/ITO) of aluminum and ITO, an APC alloy, and a deposited structure (ITO/APC/ITO) of APC alloy and ITO. The APC alloy is an alloy of silver (Ag), palladium (Pb), and Copper (Cu). The first electrode 6 may be an anode. The first electrode 6 may include a first sub electrode 61 and a second sub electrode 62.

[0068] The first sub electrode 61 may be provided on the first subpixel area 21. The first sub electrode 61 may be in contact with the first reflective electrode 51. In more detail, the first sub electrode 61 may be connected to the first parallel portion 511 of the first reflective electrode 51 connected to the first transistor 31 through the through hole 3a. Therefore, the first sub electrode 61 may be arranged in parallel with the substrate 2, whereby the driving voltage applied from the first transistor 31 may be transferred to the first sub electrode 61 through the first parallel portion 511.

[0069] The first sub electrode 61 may be provided with a plurality of first sub electrodes which may be in contact with each of the first reflective electrodes 51. The first sub electrodes 61 may include a first parallel electrode 611 which is in contact with the first parallel portion 511, a pair of second parallel electrodes 612 which are in contact with the second parallel portion 512, and a pair of third parallel

electrodes **613** which are in contact with the third parallel portion **513**. The pair of second parallel electrodes **612** may have the same length, and the pair of third parallel electrodes **613** may have the same length.

[0070] Likewise, the second sub electrode **62** may be provided with a plurality of second sub electrodes which may be in contact with each of the second reflective electrodes **52**. The second sub electrodes **62** may include a pair of first inclined electrodes **621** which are in contact with the first inclined portion **521**, a pair of second inclined electrodes **622** which are in contact with the second inclined portion **522**, and a pair of third inclined electrodes **623** which are in contact with the third inclined portion **523**. The pair of first inclined electrodes **621** may have the same length, the pair of second inclined electrodes **622** may have the same length, and the pair of third inclined electrodes **623** may have the same length.

[0071] Also, each of the pair of first inclined electrodes **621**, the pair of second inclined electrodes **622** and the pair of third inclined electrodes **623** may be provided to have the first angle  $\theta 1$  with respect to the substrate **2**. Therefore, the first parallel electrode **611** and the pair of first inclined electrodes **621**, the pair of second parallel electrodes **612** and the pair of second inclined electrodes **622**, and the pair of third parallel electrodes **613** and the pair of third inclined electrodes **623** may be arranged symmetrically based on the through hole **3a**.

[0072] The plurality of second sub electrodes **62** may be spaced apart from one another at a first spaced distance **D1**. For example, the pair of first inclined electrodes **621**, the pair of second inclined electrodes **622**, and the pair of third inclined electrodes **623** may be spaced apart from each other at the first spaced distance **D1**. The first spaced distance **D1** may mean a distance between the uppermost ends of each of the pair of first, second and third inclined electrodes **621**, **622** and **623**.

[0073] The first spaced distance **D1** may be increased at a longer distance from the substrate **2**. In this case, the direction at a longer distance from the substrate **2** may be a direction toward the encapsulation layer **10** from the substrate **2**. Therefore, the first spaced distance **D1** may gradually be increased toward the pair of first inclined electrodes **621**, the pair of second inclined electrodes **622**, and the pair of third inclined electrodes **623**. In this case, since an aperture ratio of the recessed portion **41** is gradually increased toward the upper side, light efficiency may be improved.

[0074] The first spaced distance **D1** may be at least  $0.14 \mu\text{m}$  or more. Since the first spaced distance **D1** is the shortest in the pair of first inclined electrodes **621**, the first spaced distance **D1** of the pair of first inclined electrodes **621** arranged on first stage may be  $0.14 \mu\text{m}$  or more.

[0075] If the first spaced distance **D1** of the pair of first inclined electrodes **621** is less than  $0.14 \mu\text{m}$ , the organic light emitting layers **8** which are respectively in contact with the pair of first inclined electrodes **621** may be connected with each other. In this case, since the second electrode **9** arranged on the organic light emitting layer **8** overlapped with the first parallel electrode **611** is provided in a shape parallel with the substrate **2** without being provided in a recessed shape, a spaced distance between the second electrode **9** and the pair of first inclined electrodes **621** is different from a spaced distance between the second electrode **9** and the first parallel electrode **611**. Therefore, a

problem occurs in that light emission from the organic light emitting layers **8** is not uniform. In this respect, in the display device **1** according to one embodiment of the present disclosure, as the first spaced distance **D1** is provided at  $0.14 \mu\text{m}$  or more, the spaced distance between the second electrode **9** and the first electrode **6**, that is, the thickness of the organic light emitting layer **8** is maintained uniformly to uniformly distribute a light emitting area, whereby light emission efficiency may be improved.

[0076] Referring to FIGS. **1** and **2A**, the bank **7** is provided between the plurality of subpixel areas while covering an end of the first electrode **6**. For example, the bank **7** may be provided between the first subpixel area **21** and a second subpixel area (not shown) adjacent to the first subpixel area **21**.

[0077] The bank **7** may be included in a bank area (area with slashes in FIG. **1**) surrounding the first electrode **6**. The bank **7** according to one example is to partition the first subpixel area **21** from the second subpixel area. The bank **7** serves to define a subpixel area, that is, a light emitting portion. Also, since an area where the bank **7** is formed does not emit light, the area may be defined as a non-light emitting portion. The bank **7** may be formed of an organic film such as acryl resin, epoxy resin, phenolic resin, polyamide resin, and polyimide resin. The organic light emitting layer **8** is formed on the first electrode **6** and the bank **7**.

[0078] With reference to FIG. **2A**, the bank **7** may include a bank top surface **71** and a bank inclined surface **72**.

[0079] The bank top surface **71** of the bank **7** is a surface arranged on the upper side in the bank **7**.

[0080] The bank inclined surface **72** of the bank **7** is a surface extended from the bank top surface **71** to a top surface of each of the pair of third parallel electrodes **613**. Therefore, the bank inclined surface **72** and the top surface of each of the pair of third parallel electrodes **613** may have a predetermined angle. The predetermined angle may be  $50^\circ$  or more and less than  $55^\circ$  as a width of the bank becomes narrow due to high resolution of the display device. The width of the bank may become narrow as a distance between subpixel areas becomes narrow. The predetermined angle may be the first angle  $\theta 1$ . Therefore, in the display device **1** according to one embodiment of the present disclosure, light emitted from the first subpixel area **21** may not be totally reflected to the bank **7** and may enter the inside of the bank **7**. Therefore, as the display device **1** according to one embodiment of the present disclosure comprises the second reflective electrode **52** to emit light entering the bank **7** to the outside of the bank **7**, the second reflective electrode **52** may reflect light emitted from the organic light emitting layer **8** of each stage, moving to the bank **7** to emit the light to the first subpixel area **21**.

[0081] The organic light emitting layer **8** is provided on the first electrode **6**. The organic light emitting layer **8** according to one example is a common layer commonly formed on a plurality of subpixel areas including the first subpixel area **21**, and may be a white light emitting layer emitting white light. In this case, the organic light emitting layer **8** may be formed with a tandem structure including more than 2 stacks. Each of the stacks may include a hole transporting layer (HTL), at least one light emitting layer, and an electron transporting layer (ETL). When a high potential voltage is applied to the first electrode **6** and a low potential voltage is applied to the second electrode **9**, holes and electrons are transferred to the organic light emitting

layer **8** through the hole transporting layer and the electron transporting layer, respectively and are combined with each other in the organic light emitting layer **8** to emit light.

[0082] For example, the organic light emitting layer **8** is comprised of a plurality of organic layers, wherein the plurality of organic layers include a first stack, a second stack, and a charge generating layer provided between the first stack and the second stack. The first stack may include a first hole transporting layer, a first light emitting layer emitting light of a first color, and a first electron transporting layer. The second stack may include a second hole transporting layer, a second light emitting layer emitting light of a second color, and a second electron transporting layer.

[0083] Also, the charge generating layer may be formed between the stacks. The charge generating layer may include an n-type charge generating layer arranged to be adjacent to the first stack and a p-type charge generating layer formed on the n-type charge generating layer and arranged to be adjacent to the second stack. The n-type charge generating layer injects electrons into the first stack, and the p-type charge generating layer injects holes into the second stack. The n-type charge generating layer may be comprised of an organic layer doped with alkali metal such as Li, Na, K, or Cs or alkali earth metal such as Mg, Sr, Ba, or Ra. The p-type charge generating layer may be made by doping a dopant on an organic material that is capable of transporting holes.

[0084] The organic light emitting layer **8** may include a plurality of first organic light emitting layers **81** which are in contact with the first sub electrodes **61**, and a plurality of second organic light emitting layers **82** which are in contact with the second sub electrodes **62**. The plurality of first organic light emitting layers **81** and the plurality of second organic light emitting layers **82** may be connected to each other. Since the first organic light emitting layers **81** are in contact with the first sub electrodes **61**, the first organic light emitting layers **81** may be arranged in parallel with the substrate **2**. Since the second organic light emitting layers **82** are in contact with the second sub electrodes **62**, the second organic light emitting layers **82** may be arranged to be inclined with respect to the substrate **2**, wherein the inclined angle may be a first angle  $\theta_1$ . The first angle  $\theta_1$  may range from  $20^\circ$  to  $70^\circ$ , preferably  $50^\circ$  to  $55^\circ$ .

[0085] The first organic light emitting layers **81** may be formed to be thicker than the second organic light emitting layers **82**. Since the second organic light emitting layers **82** are arranged at the first angle  $\theta_1$  due to the first electrode **6** which is arranged at the first angle  $\theta_1$  corresponding to  $20^\circ$  to  $70^\circ$  with respect to the substrate **2** when the organic light emitting layer **8** is deposited on the first electrode **6**, the second organic light emitting layers **82** may be thinner than the first organic light emitting layers **81** arranged in parallel with the substrate **2**. That is, the first organic light emitting layers **81** may be thicker than the second organic light emitting layers **82**. For example, the first organic light emitting layers **81** may be thicker than the second organic light emitting layers **82** as much as 50% or more. If the angle of the second organic light emitting layer **82** is  $90^\circ$  or less by exceeding  $70^\circ$  with respect to the substrate **2**, the thickness of the second organic light emitting layer **82** which is in contact with the second sub electrodes **62** is remarkably reduced when the organic light emitting layer **8** is deposited on the first electrode **6**, whereby a problem occurs in that unstable driving is caused. Therefore, the display device **1** according to one embodiment of the present disclosure

comprises the first electrode **6** so that the angle of the second organic light emitting layers **82** ranges from  $20^\circ$  to  $70^\circ$  with respect to the substrate **2**, whereby luminance may be prevented from being reduced due to light spread in the first subpixel area **21** and the thickness of the second organic light emitting layer **82** may be prevented from being remarkably reduced to avoid unstable driving according to current concentration.

[0086] The second electrode **9** is provided on the organic light emitting layer **8**. The second electrode **9** according to one example is a common layer commonly formed on the plurality of subpixel areas including the first subpixel area **21**. In more detail, the second electrode **9** may be formed to be in contact with the first organic light emitting layer **81** arranged on the recessed portion **41**, the second organic light emitting layer **82** and the other organic light emitting layers **8** arranged on a place except the recessed portion **41**. The second electrode **9** may be formed of a transparent conductive materials (TCO) such as ITO and IZO that are capable of transmitting light or a semi-transmissive conductive material such as Mg, Ag, or an alloy of Mg and Ag.

[0087] The encapsulation layer **10** may be formed on the second electrode **9**. The encapsulation layer **10** serves to prevent oxygen or water from being permeated into the organic light emitting layer **8** and the second electrode **9**. To this end, the encapsulation layer **10** may include at least one inorganic film and at least one organic film.

[0088] For example, the encapsulation layer **10** may include a first inorganic film, an organic film, and a second inorganic film. In this case, the first inorganic film is formed to cover the second electrode **9**. The organic film is formed to cover the first inorganic film. It is preferable that the organic film is formed at a sufficient thickness to prevent particles from being permeated into the organic light emitting layer **8** and the second electrode **9** by passing through the first inorganic film. The second inorganic film is formed to cover the organic film.

[0089] In FIG. 2A, only up to the encapsulation layer **10** arranged on the second electrode **9** is shown for convenience of description. In the case that an organic light emitting diode includes only white organic light emitting diode, red, green and blue color filters may be arranged on the encapsulation layer **10** to embody red, green and blue colors. In this case, a black matrix (BM) may be arranged between the color filters to partition the color filters. In the case that the organic light emitting diode includes red, green and blue organic light emitting diodes to emit light of red, green and blue colors, the red, green and blue color filters may not be arranged on the encapsulation layer **10**.

[0090] Hereinafter, the reason why the recessed portion **41**, the reflective electrode **5** and the first electrode **6** of the display device **1** according to one embodiment of the present disclosure are provided with N stages (N is an integer greater than 1), that is, multiple stages will be described with reference to a light path shown in FIG. 2A.

[0091] First of all, light emitted from each of the first organic light emitting layer **81** and the second organic light emitting layer **82** arranged on first stage closest to the substrate **2** may include direct light headed for the first subpixel area **21** in a direction vertical to the substrate **2** or a direction close to the vertical direction and side light headed for the pair of first inclined portions **521**. The direct light may be the other light except the side light. Since the direct light of first stage is emitted from the deepest position

of the recessed portion 41 but is emitted to the first subpixel area 21, it may contribute to enhancement of light efficiency. The side light of first stage may move to the first inclined portion 521 by a wave guide of the first organic light emitting layer 81 arranged on first stage, or light may be emitted from an edge portion of the first organic light emitting layer 81 or the second organic light emitting layer 82 arranged on first stage and move to the first inclined portion 521. The side light of first stage may enter the first inclined electrode 621, may be reflected to the first inclined portion 521 and then emitted to the outside of the first inclined electrode 621. In this case, since the first inclined portion 521 has a first angle  $\theta_1$  with respect to the substrate 2, the light reflected to the first inclined portion 521 may be emitted to the first subpixel area 21.

[0092] In connection with the light path, as shown in FIG. 2A, as the position where light is emitted from the first organic light emitting layer 81 of first stage is close to any one of the pair of first inclined portions 521 of the second reflective electrode 52, light efficiency may be enhanced.

[0093] For example, in the case that the reflective electrode 5 is provided at an edge portion of a light emitting area of  $165\ \mu\text{m} \times 165\ \mu\text{m}$ , light efficiency may be more improved than the case that the reflective electrode 5 is not provided, as much as 10%. In the case that the reflective electrode 5 is provided at an edge portion of a light emitting area of  $50\ \mu\text{m} \times 200\ \mu\text{m}$ , light efficiency may be more improved than the case that the reflective electrode 5 is not provided, as much as 18% to 25%. In the case that the reflective electrode 5 is provided at an edge portion of a light emitting area of  $50\ \mu\text{m} \times 50\ \mu\text{m}$ , light efficiency may be more improved than the case that the reflective electrode 5 is not provided, as much as 46% to 70%. This means that light efficiency is increased as the light emitting position is close to the reflective electrode 5.

[0094] Therefore, in the display device 1 according to one embodiment of the present disclosure, as the distance between the light emitting position of light in the organic light emitting layer 8 and the reflective electrode 5 is reduced as much as possible, efficiency of light emitted to the first subpixel area 21 may be enhanced. In this case, the first spaced distance D1 of the pair of inclined electrodes 621 which are in contact with the pair of first inclined portions 521 may be at least  $0.14\ \mu\text{m}$  or more. Although the light path is shown based on the first organic light emitting layer 81 of first stage in FIG. 2A, it is natural that light emitted from the second organic light emitting layer 82 of first stage is reflected to the first parallel portion 511 of the first reflective electrode 51 of first stage and emitted to the first subpixel area 21. Therefore, a detailed description of the light path will be omitted.

[0095] Then, light emitted from each of the first organic light emitting layer 81 and the second organic light emitting layer 82 arranged on stages higher than first stage may include direct light headed for the first subpixel area 21 in a direction vertical to the substrate 2 or a direction close to the vertical direction and side light headed for the pair of second inclined portions 522. The direct light may be the other light except the side light. Since the direct light of second stage is emitted from the position higher than first stage to the first subpixel area 21, it may contribute to enhancement of light efficiency. The side light of second stage may move to the second inclined portion 522 by a wave guide of the first organic light emitting layer 81 arranged on second stage, or

light may be emitted from an edge portion of the first organic light emitting layer 81 or the second organic light emitting layer 82 arranged on second stage and move to the second inclined portion 522. The side light of second stage may enter the second inclined electrode 622, may be reflected to the second inclined portion 522 and then emitted to the outside of the second inclined electrode 622. In this case, since the second inclined portion 522 has a first angle  $\theta_1$  with respect to the substrate 2, the light reflected to the second inclined portion 522 may be emitted to the first subpixel area 21.

[0096] In connection with the light path, as shown in FIG. 2A, as the position where light is emitted from the first organic light emitting layer 81 of second stage is close to any one of the pair of second inclined portions 522 of the second reflective electrode 52, light efficiency may be enhanced for the same reason for enhancement of light efficiency at first stage. Also, as the position where light is emitted from the second organic light emitting layer 82 of second stage is close to the pair of second parallel portions 512 of the first reflective electrode 51, light efficiency may be enhanced.

[0097] Then, light emitted from each of the first organic light emitting layer 81 and the second organic light emitting layer 82 arranged on third stage higher than second stage may include direct light headed for the first subpixel area 21 in a direction vertical to the substrate 2 or a direction close to the vertical direction and side light headed for the pair of third inclined portions 523. The direct light may be the other light except the side light. Since the direct light of third stage is emitted from the position higher than second stage to the first subpixel area 21, it may contribute to enhancement of light efficiency. The side light of third stage may move to the third inclined portion 523 by a wave guide of the first organic light emitting layer 81 arranged on third stage, or light may move from an edge portion of the first organic light emitting layer 81 or the second organic light emitting layer 82 arranged on third stage to the third inclined portion 523. The side light of third stage may enter the third inclined electrode 623, may be reflected to the third inclined portion 523 and then emitted to the outside of the third inclined electrode 623. In this case, since the third inclined portion 523 has a first angle  $\theta_1$  with respect to the substrate 2, the light reflected to the third inclined portion 523 may be emitted to the first subpixel area 21.

[0098] In connection with the light path, as shown in FIG. 2A, as the position where light is emitted from the first organic light emitting layer of third stage is close to any one of the pair of third inclined portions 523 of the second reflective electrode 52, light efficiency may be enhanced for the same reason for enhancement of light efficiency at first stage and second stage. Also, as the position where light is emitted from the second organic light emitting layer 82 of third stage is close to the pair of third parallel portions 513 of the first reflective electrode 51, light efficiency may be enhanced.

[0099] As a result, in the display device 1 according to one embodiment of the present disclosure, as the recessed portion 41, the reflective electrode 5 and the first electrode 6 are provided with multiple stages, the distance between the light emitting position of light in the organic light emitting layer 8 arranged on each stage and the reflective electrode 5 is reduced as much as possible, efficiency of light emitted to the first subpixel area 21 may be enhanced.

**[0100]** FIG. 3A is a brief cross-sectional view illustrating a display device according to the second embodiment of the present disclosure, FIG. 3B is a brief enlarged view illustrating a part B shown in FIG. 3A, and FIG. 3C is a brief enlarged view illustrating a part C shown in FIG. 3A.

**[0101]** Referring to FIGS. 3A to 3C, the display device 1 according to the second embodiment of the present disclosure is the same as the display device 1 according to one embodiment of the present disclosure of FIG. 2A except that the recessed portion 41, the reflective electrode 5 and the first electrode 6 are changed. Therefore, the same reference numbers will be used throughout the drawings to refer to the same or like parts. Hereinafter, the elements different from those of the display device 1 according to one embodiment of the present disclosure will be described.

**[0102]** In the display device according to FIG. 2A, since the recessed portion 41 is formed as one groove and provided with three stages, the reflective electrode 5 and the first electrode 6 arranged on the recessed portion 41 are provided with three stages. Therefore, in the display device according to FIG. 2A, the first spaced distance D1 of each stage of the first electrode 6 is gradually increased at a longer distance from the substrate 2.

**[0103]** On the other hand, in the display device 1 according to FIG. 3A, since the recessed portion 41 is formed as two grooves and provided with two stages, the reflective electrode 5 arranged on the recessed portion 41 and the first electrode 6 are provided with two stages. The recessed portion 41 arranged on first stage of the display device 1 according to FIG. 3A includes a first recessed portion 411, a second recessed portion 411', and a convex portion 412 arranged between the first recessed portion 411 and the second recessed portion 411'. The recessed portion 41 arranged on two stages of the display device 1 according to FIG. 3A is provided in the same type as three stages of the recessed portion 41 of the display device according to FIG. 2A. In the display device 1 according to FIG. 3A, as the convex portion 412 is arranged between the first recessed portion 411 and the second recessed portion 411', an aperture rate of the recessed portion 41 may suddenly be increased if one stage is changed to two stages.

**[0104]** Referring to FIGS. 3A to 3C, the display device 1 according to the second embodiment of the present disclosure includes a first recessed portion 411, a second recessed portion 411', and a convex portion 412.

**[0105]** The first recessed portion 411 and the second recessed portion 411' may be formed in a dented shape of the insulating layer 4 through at least one of various patterning methods and deposition methods in the same manner as the recessed portion 41 of the display device 1 according to one embodiment of the present disclosure. On the other hand, the convex portion 412 may be formed naturally as the first recessed portion 411 and the second recessed portion 411' are formed. The convex portion 412 may be formed by being deposited between the first recessed portion 411 and the second recessed portion 411'.

**[0106]** The first recessed portion 411 and the second recessed portion 411' may be provided with N stages (N is an integer greater than 1). For example, the first recessed portion 411 and the second recessed portion 411' may be provided with two stages as shown in FIG. 3A. The convex portion 412 may be provided to be protruded in a direction opposite to the first and second recessed portions 411 and 411' between the first recessed portion 411 and the second

recessed portion 411'. Although the convex portion 412 may be provided with one stage as shown in FIG. 3A, the convex portion 412 may be provided with multiple stages in the same manner as the first and second recessed portions 411 and 411'.

**[0107]** The first recessed portion 411 is arranged at one side of a subpixel area. For example, the first recessed portion 411 may be arranged at the upper side of the first subpixel area 21. Therefore, the first recessed portion 411 may be a light emitting area for allowing the upper side of the first subpixel area 21 to emit light.

**[0108]** The second recessed portion 411' may be arranged at the other side of the first subpixel area 21. The second recessed portion 411' may be a light emitting area for allowing the side of the first subpixel area 21 to emit light. Therefore, the first recessed portion 411 and the second recessed portion 411' may be light emitting areas for allowing one side and the other side, that is, all of the first subpixel area 21 to emit light.

**[0109]** A transistor for applying a driving voltage to the first recessed portion 411 and the second recessed portion 411', for example, the first transistor 31 of the first subpixel area 21 may be provided to overlap any one of the first recessed portion 411 and the second recessed portion 411'.

**[0110]** As shown in FIG. 3A, if the first transistor 31 is arranged to overlap the first recessed portion 411, the first reflective electrode 51 arranged on the first recessed portion 411 may be connected to the first transistor 31 through the through hole 3a.

**[0111]** The first recessed portion 411 may include a plurality of recessed bottom surfaces 41a parallel with the substrate 2, and a plurality of recessed sides 41b inclined with respect to the substrate 2. The plurality of recessed bottom surfaces 41a may include a first stage recessed bottom surface 41aa and a second stage recessed bottom surface 41ab. The plurality of recessed sides 41b may include a first stage recessed side 41ba and a second stage recessed side 41bb.

**[0112]** Since the recessed bottom surface 41a including the first stage recessed bottom surface 41aa and the second stage recessed bottom surface 41ab and the recessed side 41b including the first stage recessed side 41ba and the second stage recessed side 41bb are the same as those of the display device 1 according to one embodiment of the present disclosure except that they are arranged on the first recessed portion 411, their description will be omitted. The elements different from those of the display device 1 according to one embodiment of the present disclosure will be described.

**[0113]** In the display device 1 according to the second embodiment of the present disclosure, if the first transistor 31 is provided to overlap the first recessed portion 411 as shown in FIG. 3A, the first recessed portion 411 and the second recessed portion 411' may be provided symmetrically based on the convex portion 412 except that the reflective electrode 5 arranged on the first recessed portion 411 is connected to the first transistor 31.

**[0114]** The second recessed portion 411' may include a plurality of recessed bottom surfaces 41a' parallel with the substrate 2, and a plurality of recessed sides 41b' inclined with respect to the substrate 2. The plurality of recessed bottom surfaces 41a' may include a first stage recessed bottom surface 41aa' and a second stage recessed bottom

surface **41ab'**. The plurality of recessed sides **41b'** may include a first stage recessed side **41ba'** and a second stage recessed side **41bb'**.

[0115] In the display device **1** according to the second embodiment of the present disclosure, since two recessed portions **41** are provided, the first stage recessed bottom surface **41aa** and the first stage recessed bottom surface **41aa'** may be provided in pairs unlike the display device **1** according to one embodiment of the present disclosure, and the first stage recessed bottom surface **41aa** and the first stage recessed bottom surface **41aa'** may be provided to be symmetrical with each other except that the through hole **3a** for connecting the reflective electrode **5** to the first transistor **31** is formed as described above.

[0116] The first stage recessed side **41ba** of the first recessed portion **411** and the first stage recessed side **41ba'** of the second recessed portion **411'** may be provided in pairs, and may be provided symmetrically based on the convex portion **412**. Each of the first stage recessed portion **41ba** and the first stage recessed side **41ba'** may have a second angle  $\theta_2$  with respect to the substrate **2**.

[0117] Likewise, each of the second stage recessed bottom surface **41ab** and the second stage recessed side **41bb** of the first recessed portion **411** and each of the second stage recessed bottom surface **41ab'** and the second stage recessed side **41bb'** of the second recessed portion **411'** may be provided symmetrically based on the convex portion **412**. Each of the second stage recessed side **41bb** and the second stage recessed side **41bb'** may have a second angle  $\theta_2$  with respect to the substrate **2**. The second angle  $\theta_2$  may range from  $20^\circ$  to  $70^\circ$ , preferably from  $50^\circ$  to  $55^\circ$ .

[0118] As a result, the display device **1** according to the second embodiment of the present disclosure may have a similar structure to the display device **1** according to one embodiment of the present disclosure except that the first recessed portion **411** and the second recessed portion **411'** are provided with two stages, the convex portion **412** is arranged between the first recessed portion **411** and the second recessed portion **411'**, and a spaced distance between a light emitting portion at first stage of each of the first recessed portion **411** and the second recessed portion **411'** and the reflective electrode **5** may be reduced due to the convex portion **412** arranged on first stage.

[0119] The convex portion **412** may include a convex top surface **412a** and a convex side **412b**. The convex top surface **412a** is parallel with the substrate **2**, and may be arranged at an upper side of the convex portion **412**. The convex top surface **412a** may be arranged on a relatively higher position than the first stage recessed bottom surface **41aa** and the first stage recessed bottom surface **41aa'**.

[0120] The convex side **412b** is inclined toward the substrate **2**, and may connect both ends of the convex top surface **412a** with a top surface of the circuit element layer **3**. The convex side **412b** may be provided with a pair of convex sides, which may respectively be arranged toward the first recessed portion **411** and the second recessed portion **411'**. The pair of convex sides **412b** may be provided symmetrically.

[0121] The reflective electrode **5** is to reflect light emitted from the organic light emitting layer **8** toward the first subpixel area **21**, and may include a first reflective electrode **51** parallel with the substrate **2** and a second reflective electrode **52** inclined toward the substrate **2**.

[0122] The first reflective electrode **51** may include a first parallel portion **511** which is in contact with the first stage recessed bottom surface **41aa** of the first recessed portion **411**, a second parallel portion **512** which is in contact with the second stage recessed bottom surface **41ab**, a first parallel portion **511'** which is in contact with the first stage recessed bottom surface **41aa'** of the second recessed portion **411'**, and a second parallel portion **512'** which is in contact with the second stage recessed bottom surface **41ab'** of the second recessed portion **411'**.

[0123] The first parallel portion **511** and the first parallel portion **511'**, and the second parallel portion **512** and the second parallel portion **512'** may be provided symmetrically based on the convex portion **412**.

[0124] The first reflective electrode **51** may further include a convex parallel portion **513** which is in contact with the convex top surface **412a**. The convex parallel portion **513** may be arranged at the same height as that of at least one of the plurality of first reflective electrodes **51** arranged on the first recessed portion **411**, that is, the first parallel portion **511** and the second parallel portion **512**. For example, as shown in FIG. 3A, the convex parallel portion **513** may be arranged at the same height as that of the second parallel portion **512**. Therefore, as the convex portion **412** protruded toward the encapsulation layer **10** may be provided between the first recessed portion **411** and the second recessed portion **411'**, the spaced distance between the light emitting position of each of the first recessed portion **411** and the second recessed portion **411'** at first stage and the reflective electrode **5** may be reduced, whereby light efficiency may be enhanced.

[0125] The second reflective electrode **52** may include a first recessed reflective electrode arranged on the first recessed portion **411** and a second recessed reflective electrode arranged on the second recessed portion **411'**.

[0126] The first recessed reflective electrode may include a first inclined portion **521** which is in contact with the first stage recessed side **41ba** of the first recessed portion **411** and a second inclined portion **522** which is in contact with the second stage recessed side **41bb**.

[0127] The second recessed reflective electrode may include a first inclined portion **521'** which is in contact with the first stage recessed side **41ba'** of the second recessed portion **411'** and a second inclined portion **522'** which is in contact with the second stage recessed side **41bb'**.

[0128] The first inclined portion **521** and the first inclined portion **521'**, and the second inclined portion **522** and the second inclined portion **522'** may be provided symmetrically based on the convex portion **412**.

[0129] Each of the first inclined portion **521**, the first inclined portion **521'**, the second inclined portion **522** and the second inclined portion **522'** of the second reflective electrode **52** may have a second angle  $\theta_2$  with respect to the substrate **2**. The second angle  $\theta_2$  may range from  $20^\circ$  to  $70^\circ$ , preferably from  $50^\circ$  to  $55^\circ$ .

[0130] If the second angle  $\theta_2$  is less than  $20^\circ$ , since the second reflective electrode **52** too lies down with respect to the substrate **2**, a reflective area where the second reflective electrode **52** reflects light is more widened than the case that the second angle  $\theta_2$  is  $20^\circ$  or more, that is, light is spread, whereby luminance of light may be deteriorated. Therefore, the user may recognize a blurred image.

[0131] If the second angle  $\theta_2$  exceeds  $70^\circ$ , the second reflective electrode **52** is too erect with respect to the

substrate **2**, whereby the second reflective electrode **52** reflects light toward another subpixel area adjacent to the first subpixel area **21** as compared with the case that the second angle  $\theta 2$  is  $70^\circ$  or less. For this reason, a problem occurs in that a color mixture occurs.

[0132] The expression that the second reflective electrode **52** lies down means that the second reflective electrode **52** is arranged to be close to an angle parallel with the substrate **2**, that is,  $0^\circ$  based on the substrate **2**. The expression that the second reflective electrode **52** is erect means that the second reflective electrode **52** is arranged to be close to an angle vertical to the substrate **2**, that is,  $90^\circ$  based on the substrate **2**.

[0133] The second reflective electrode **52** may include a first convex reflective electrode **523** arranged on the convex portion **412** to face the first inclined portion **521** of the first recessed reflective electrode, and a second convex reflective electrode **524** arranged on the convex portion **412** to face the first inclined portion **521'** of the second recessed reflective electrode.

[0134] Each of the first convex reflective electrode **523** and the second convex reflective electrode **524** may be in contact with the convex side **412b** to reflect light of the organic light emitting layer **8** to the first subpixel area **21**.

[0135] The first inclined portion **521** and the first convex reflective electrode **523** may be provided symmetrically based on the first parallel portion **511**, and the first inclined portion **521'** and the second convex reflective electrode **524** may be provided symmetrically based on the first parallel portion **511'**.

[0136] The first electrode **6** is an anode, and is provided on the reflective electrode **5** while being overlapped with the first recessed portion **411**, the second recessed portion **411'** and the convex portion **412**. The first electrode **6** may include a first sub electrode **61** which is in contact with the first reflective electrode **51**, and a second sub electrode **62** which is in contact with the second reflective electrode **52**. The first sub electrode **61** and the second sub electrode **62** may be connected to one electrode.

[0137] The first sub electrode **61** may include a first parallel electrode **611** which is in contact with the first parallel portion **511**, a second parallel electrode **612** which is in contact with the second parallel portion **512** of the first recessed portion **411**, a first parallel electrode **611'** which is in contact with the first parallel portion **511'** of the second recessed portion **411'**, and a second parallel electrode **612'** which is in contact with the second parallel portion **512'** of the second recessed portion **411'**. The first sub electrode **61** may further include a convex electrode **613** which is in contact with the convex parallel portion **513** of the convex portion **412**.

[0138] The second sub electrode **62** may include a first recessed sub electrode **621** which is in contact with the first inclined portion **521** of the first recessed portion **411**, a second recessed sub electrode **622** which is in contact with the second inclined portion **522** of the first recessed portion **411**, a second sub electrode **621'** which is in contact with the first inclined portion **521'** of the second recessed portion **411'**, and a second recessed sub electrode **622'** which is in contact with the second inclined portion **522'** of the second recessed portion **411'**. The second sub electrode **62** may further include a first convex sub electrode **623** which is in contact with the first convex reflective electrode **523** of the

convex portion **412**, and a second convex sub electrode **624** which is in contact with the second convex reflective electrode **524**.

[0139] As shown in FIGS. 3B and 3C, the first recessed sub electrode **621** and the first convex sub electrode **623** may be spaced apart from each other at a second spaced distance **D2**, and the second recessed sub electrode **621'** and the second convex sub electrode **624** may be spaced apart from each other at a third spaced distance **D3**.

[0140] The second spaced distance **D2** and the third spaced distance **D3** may be provided in the same manner. The second spaced distance **D2** may be  $0.14 \mu\text{m}$  or more. If the second spaced distance **D2** is less than  $0.14 \mu\text{m}$ , the organic light emitting layers **8** which are respectively in contact with the first recessed sub electrode **621** and the first convex sub electrode **623** may be connected with each other. In this case, since the second electrode **9** arranged on the organic light emitting layer **8** overlapped with the first parallel electrode **611** is arranged in a shape parallel with the substrate **2** without being formed in a recessed shape, a spaced distance between the first electrode **6** and the second electrode **9** at first stage of the first recessed portion **411**, that is, the thickness of the organic light emitting layer **8** is changed, whereby a problem occurs in that light emission from the organic light emitting layers **8** is not uniform. Therefore, in the display device **1** according to the second embodiment of the present disclosure, as the second spaced distance **D2** and the third spaced distance **D3** equal to the second spaced distance **D2** are provided at  $0.14 \mu\text{m}$  or more, the spaced distance between the second electrode **9** and the first electrode **6** at first stage, that is, the thickness of the organic light emitting layer **8** is maintained uniformly to uniformly distribute a light emitting area, whereby light emission efficiency may be enhanced.

[0141] Hereinafter, the reason why the first recessed portion **411**, the second recessed portion **411'**, the reflective electrode **5** and the first electrode **6** of the display device **1** according to the second embodiment of the present disclosure are provided with **N** stages (**N** is an integer greater than 1), that is, multiple stages will be described with reference to a light path shown in FIG. 3A. Since the first recessed portion **411** and the second recessed portion **411'** are provided symmetrically based on the convex portion **412**, description of the second recessed portion **411'** and the convex portion **412** will be omitted, and description will be given based on the first recessed portion **411** and the convex portion **412**.

[0142] First of all, light emitted from each of the first organic light emitting layer **81** and the second organic light emitting layer **82** arranged on first stage closest to the substrate **2** may include direct light headed for the first subpixel area **21** in a direction vertical to the substrate **2** or a direction close to the vertical direction and side light headed for the first inclined portion **521** and the first convex reflective electrode **523**. The direct light may be the other light except the side light. Since the direct light of first stage is emitted from the deepest position of the first recessed portion **411** but is emitted to the first subpixel area **21**, it may contribute to enhancement of light efficiency. The side light of first stage may move to the first inclined portion **521** and the first convex reflective electrode **523** by a wave guide of the first organic light emitting layer **81** arranged on first stage, or light may be emitted from an edge portion of the first organic light emitting layer **81** or the second organic

light emitting layer **82** arranged on first stage and move to the first inclined portion **521** and the first convex reflective electrode **523**. The side light of first stage may enter the first inclined electrode **621** and the first convex sub electrode **623**, may be reflected to the first inclined portion **521** and the first convex reflective electrode **523** and then emitted to the outside of the first inclined electrode **621** and the first convex sub electrode **623**. In this case, since the first inclined portion **521** and the first convex reflective electrode **523** have a second angle  $\theta_2$  with respect to the substrate **2**, the light reflected to the first inclined portion **521** and the first convex reflective electrode **523** may be emitted to the first subpixel area **21**.

[0143] In connection with the light path, as shown in FIG. 3A, as the position where light is emitted from the first organic light emitting layer **81** of first stage is close to any one of the first inclined portion **521** and the first convex reflective electrode **523**, light efficiency may be enhanced as described in the display device **1** according to one embodiment of the present disclosure.

[0144] Although the light path is shown based on the first organic light emitting layer **81** of first stage in FIG. 3A, it is natural that light emitted from the second organic light emitting layer **82** of first stage is reflected to the first parallel portion **511** of the first reflective electrode **51** of first stage and emitted to the first subpixel area **21**. Therefore, a detailed description of the light path will be omitted.

[0145] Then, light emitted from each of the first organic light emitting layer **81** and the second organic light emitting layer **82** arranged on second stage higher than first stage may include direct light headed for the first subpixel area **21** in a direction vertical to the substrate **2** or a direction close to the vertical direction and side light headed for the second inclined portion **522**. The direct light may be the other light except the side light. Since the direct light of second stage is emitted from the position higher than first stage to the first subpixel area **21**, it may contribute to enhancement of light efficiency. The side light of second stage may move to the second inclined portion **522** by a wave guide of the first organic light emitting layer **81** arranged on second stage, or light may be emitted from an edge portion of the first organic light emitting layer **81** or the second organic light emitting layer **82** arranged on second stage and move to the second inclined portion **522**. The side light of second stage of the first recessed portion **411** may enter the second inclined electrode **622**, may be reflected to the second inclined portion **522** and then emitted to the outside of the second inclined electrode **622**. In this case, since the second inclined portion **522** has a second angle  $\theta_2$  with respect to the substrate **2**, the light reflected to the second inclined portion **522** may be emitted to the first subpixel area **21**.

[0146] In connection with the light path, as shown in FIG. 3A, as the position where light is emitted from the first organic light emitting layer **81** of second stage is close to the second inclined portion **522** of the second reflective electrode **52**, light efficiency may be enhanced for the same reason for enhancement of light efficiency at first stage. Also, as the position where light is emitted from the second organic light emitting layer **82** of second stage is close to the second parallel portion **512** of the first reflective electrode **51**, light efficiency may be enhanced.

[0147] As a result, in the display device **1** according to the second embodiment of the present disclosure, as the first recessed portion **411**, the second recessed portion **411'**, the

reflective electrode **5** and the first electrode **6** are provided with multiple stages, and the convex portion **412** is arranged between the first recessed portion **411** and the second recessed portion **411'**, the distance between the light emitting position of light in the organic light emitting layer **8** arranged on each stage and the reflective electrode **5** is reduced as much as possible, efficiency of light emitted to the first subpixel area **21** may be enhanced.

[0148] FIG. 4 is a brief cross-sectional view illustrating a display device according to the third embodiment of the present disclosure.

[0149] With reference to FIG. 4, the display device **1** according to the third embodiment of the present disclosure is the same as the display device **1** according to FIG. 3A except that the first reflective electrode **51** provided on the second recessed portion **411'** is connected to the first transistor **31**. Therefore, the same reference numbers will be used throughout the drawings to refer to the same or like parts. Hereinafter, only the elements different from those of the display device **1** according to FIG. 3A will be described.

[0150] In the display device according to FIG. 3A, the first transistor **31** is connected to only the first reflective electrode **51** provided on the first recessed portion **411**. Therefore, the driving voltage of the first transistor **31** may be applied from the first reflective electrode **51** of the first recessed portion **411** to the first reflective electrode **51** provided on the second recessed portion **411'**.

[0151] On the other hand, in the display device according to FIG. 4, the first reflective electrode **51** arranged on each of the first recessed portion **411** and the second recessed portion **411'** may be connected to the first transistor **31**. In more detail, the first parallel portion **511** provided on the first recessed portion **411** may be connected to the first transistor **31** through the through hole **3a**, and the first parallel portion **511'** provided on the second recessed portion **411'** may be connected to the first transistor **31** through a first through hole **3b** and a connection electrode CE.

[0152] The first through hole **3b** is a hole formed to pass through the circuit element layer **3** overlapped with the second recessed portion **411'** so that the first parallel portion **511'** may be connected to the first transistor **31**. The first parallel portion **511'** may be connected to the connection electrode CE arranged on the circuit element layer **3** through the first through hole **3b**.

[0153] The connection electrode CE is to connect the first transistor **31** with the first parallel portion **511'**, and may be formed in the circuit element layer **3**. The connection electrode CE may be formed of a material that includes a metal material to enhance conductivity for transferring the driving voltage of the first transistor **31** to the first parallel portion **511'**.

[0154] Therefore, in the display device **1** according to the third embodiment of the present disclosure, since the driving voltage of the first transistor **31** may simultaneously be applied to the first reflective electrodes **51** respectively arranged on the first recessed portion **411** and the second recessed portion **411'**, it is possible to improve light efficiency while reducing a difference in response of the organic light emitting layers **8** on the first recessed portion **411** and the second recessed portion **411'** as compared with the case that the driving voltage is applied to only the first reflective electrode **51** of the first recessed portion **411**.

[0155] In the display device **1** according to the third embodiment of the present disclosure, the first reflective

electrode **51** of the second recessed portion **411'** is connected to the first transistor **31** through the connection electrode CE as described above. However, without limitation to this case, a length of the first transistor **31** may be increased to reach the second recessed portion **411'** without the connection electrode CE, whereby the first reflective electrode **51** of the second recessed portion **411'** may be connected with the first transistor **31**.

[0156] FIGS. **5A** to **5C** are views illustrating a display device according to another embodiment of the present disclosure, and relate to a head-mounted display (HMD) device. FIG. **5A** is a brief perspective view of a head-mounted display device, FIG. **5B** is a brief plane view of a virtual reality (VR) structure, and FIG. **5C** is a brief cross-sectional view of an augmented reality (AR) structure.

[0157] As will be aware of it from FIG. **5A**, a head mounted display device according to present disclosure comprises a storage case **11** and a head mounted band **30**.

[0158] The storage case **11** stores elements such as a display device, a lens array, and an ocular lens.

[0159] The head mounted band **30** is fixed to the storage case **11**. The head mounted band **30** is formed to surround a top surface and both sides of a user's head, but is not limited to this example. The head mounted band **30** is to fix a head mounted display device to a user's head and may be replaced with a structure of a shape of a glasses frame or a helmet shape.

[0160] As will be aware of it from FIG. **5B**, the head mounted display device **1** of a virtual reality (VR) structure according to the present disclosure may include a left eye display device **2a**, a right eye display device **2b**, a lens array **12**, a left eye ocular lens **20a**, and a right eye ocular lens **20b**.

[0161] The left eye display device **2a**, the right eye display device **2b**, the lens array **12**, the left eye ocular lens **20a** and the right eye ocular lens **20b** are stored in the storage case **11** described above.

[0162] The left eye display device **2a** and the right eye display device **2b** may display the same image, and in this case, a user may view 2D image. Alternatively, the left eye display device **2a** may display a left eye image and the right eye display device **2b** may display a right eye image, and in this case, a user may view a 3D image. Each of the left eye display device **2a** and the right eye display device **2b** may be comprised of a display device according to FIGS. **1** to **4** described above. For example, each of the left eye display device **2a** and the right eye display device **2b** may be an organic light emitting display device.

[0163] Each of the left eye display device **2a** and the right eye display device **2b** may include a plurality of subpixel areas, an insulating layer **4**, a reflective electrode **5**, a first electrode **6**, a bank **7**, an organic light emitting layer **8**, a second electrode **9**, and an encapsulation layer **10**, may display various images by combining colors of light emitted from each of the subpixel areas in various manners.

[0164] The lens array **12** may be provided between the left eye ocular lens **20a** and the left eye display device **2a** by being spaced apart from each of the left eye ocular lens **20a** and the left eye display device **2a**. That is, the lens array **12** may be arranged in front of the left eye ocular lens **20a** and behind the left eye display device **2a**. Also, the lens array **12** may be provided between the right eye ocular lens **20b** and the right eye display device **2b** by being spaced apart from each of the right eye ocular lens **20b** and the right eye display

device **2b**. That is, the lens array **12** may be arranged in front of the right eye ocular lens **20b** and behind the right eye display device **2b**.

[0165] The lens array **12** may be a micro lens array. The lens array **12** may be replaced with a pin hole array. Due to the lens array **12**, images displayed on a left eye display device **2a** or a right eye display device **2b** may be viewed to be magnified to a user.

[0166] A left eye LE of a user may be arranged in the left eye ocular lens **20a**, and a right eye RE of a user may be arranged in the right eye ocular lens **20b**.

[0167] As will be aware of it from FIG. **5C**, a head mounted display device of an augmented reality (AR) structure according to the present disclosure includes a left eye display device **2a**, a lens array **12**, a left eye ocular lens **20a**, a transmissive reflection portion **13**, and a transmissive window **14**. Although only a structure for a left eye is shown in FIG. **5C** for convenience, a structure for a right eye is the same as the structure for the left eye.

[0168] The left eye display device **2a**, the lens array **12**, the left eye ocular lens **20a**, the transmissive reflection portion **13**, and the transmissive window **14** are stored in the aforementioned storage case **11**.

[0169] The left eye display device **2a** may be arranged at one side of the transmissive reflection portion **13**, for example, at an upper side, without covering the transmissive window **14**. Therefore, the left eye display device **2a** may provide the transmissive reflection portion **13** with an image without covering an outer background viewed through the transmissive window **14**.

[0170] The left eye display device **2a** may be comprised of an electroluminescence display device according to FIGS. **1** to **4** described above. In this case, the top portion corresponding to the surface where images are displayed in FIGS. **1** to **4**, for example, the encapsulation layer **10** or a color filter (not shown) faces the transmissive reflection portion **13**.

[0171] The lens array **12** may be provided between the left eye ocular lens **20a** and the transmissive reflection portion **13**.

[0172] A left eye of a user is arranged in the left eye ocular lens **20a**.

[0173] The transmissive reflection portion **13** is arranged between the lens array **12** and the transmissive window **14**. The transmissive reflection portion **13** may include a reflection surface **13a** which transmits a portion of light and reflects another portion of light. The reflection surface **13a** is formed to make an image displayed on the left eye display device **2a** to proceed to the lens array **12**. Therefore, a user may view all of images displayed on the left eye display device **2a** and an outer background through the transmissive window **14**. That is, since the user may view one image by overlapping background in reality with virtual images, augmented reality (AR) may be embodied.

[0174] The transmissive window **14** is arranged in front of the transmissive reflection portion **13**.

[0175] It will be apparent to those skilled in the art that various modifications and variations can be made in the display device of the present disclosure without departing from the technical idea or scope of the disclosure. Thus, it is intended that the present disclosure cover the modifications and variations of this disclosure provided they come within the scope of the appended claims and their equivalents.

What is claimed is:

1. A display device comprising:
  - a substrate provided with a plurality of subpixel areas;
  - a circuit element layer provided on the substrate and provided with a transistor for each subpixel area;
  - an insulating layer provided on the circuit element layer and provided with a recessed portion formed to overlap the transistor;
  - a reflective electrode provided on the insulating layer and provided in the recessed portion;
  - a first electrode provided on the reflective electrode while being overlapped with the recessed portion;
  - an organic light emitting layer provided on the first electrode;
  - a bank provided between the subpixel areas while covering an end of the first electrode; and
  - a second electrode provided on the organic light emitting layer,
 wherein the recessed portion, the reflective electrode and the first electrode are provided with N stages, wherein N is an integer greater than 1.
2. The display device of claim 1, wherein the reflective electrode includes:
  - a plurality of first reflective electrodes parallel with the substrate; and
  - a plurality of second reflective electrodes inclined with respect to the substrate.
3. The display device of claim 2, wherein the first reflective electrodes are arranged at their respective heights different from each other based on the substrate.
4. The display device of claim 1, wherein the circuit element layer includes a through hole formed at a portion where the recessed portion is overlapped with the transistor, and the reflective electrode is in contact with the transistor through the through hole.
5. The display device of claim 4, wherein the recessed portion, the reflective electrode and the first electrode are arranged symmetrically based on the through hole.
6. The display device of claim 2, wherein each of the second reflective electrodes has a first angle with the substrate, and the first angle ranges from 20° to 70°.
7. The display device of claim 2, wherein the first electrode includes a plurality of first sub electrodes which are in contact with the first reflective electrodes and a plurality of second sub electrodes which are in contact with the second reflective electrodes, the organic light emitting layer includes a plurality of first organic light emitting layers which are in contact with the first sub electrodes, and a plurality of second organic light emitting layers which are in contact with the second sub electrodes, and the first organic light emitting layers are thicker than the second organic light emitting layers.
8. The display device of claim 7, wherein the second sub electrodes are spaced apart from each other at a first spaced distance which is increased at a longer distance from the substrate.
9. The display device of claim 8, wherein the first spaced distance is 0.14 in or more.
10. The display device of claim 3, wherein the recessed portion includes:
  - a first recessed portion arranged at one side of the subpixel area;
  - a second recessed portion arranged at the other side of the subpixel area; and
  - a convex portion arranged between the first recessed portion and the second recessed portion.
11. The display device of claim 10, wherein each of the second reflective electrodes respectively arranged on the first and second recessed portions and the convex portion has a second angle with the substrate, and the second angle ranges from 20° to 70°.
12. The display device of claim 10, wherein the transistor is provided to overlap any one of the first recessed portion and the second recessed portion.
13. The display device of claim 12, wherein the first reflective electrode arranged on each of the first recessed portion and the second recessed portion is connected to the transistor.
14. The display device of claim 10, wherein the first reflective electrode arranged on the convex portion is arranged at the same height as that of at least one of the plurality of first reflective electrodes arranged on the first recessed portion.
15. The display device of claim 10, wherein the second reflective electrode includes a first recessed reflective electrode arranged on the first recessed portion and a second recessed reflective electrode arranged on the second recessed portion, and the first recessed reflective electrode and the second recessed reflective electrode are symmetrical based on the convex portion.
16. The display device of claim 15, wherein the second reflective electrode includes a first convex reflective electrode arranged on the convex portion to face the first recessed reflective electrode, and a second convex reflective electrode arranged on the convex portion to face the second recessed reflective electrode,
  - the first electrode includes a first recessed sub electrode which is in contact with the first recessed reflective electrode, a first convex sub electrode which is in contact with the first convex reflective electrode, a second recessed sub electrode which is in contact with the second recessed reflective electrode, and a second convex sub electrode which is in contact with the second convex reflective electrode,
  - the first recessed sub electrode and the first convex sub electrode are spaced apart from each other at a second spaced distance and the second recessed sub electrode and the second convex sub electrode are spaced apart from each other at a third spaced distance, and the second spaced distance and the third spaced distance are equal to each other.
17. The display device of claim 16, wherein the second spaced distance is 0.14 μm or more.
18. The display device of claim 1, further comprising a lens array spaced apart from the substrate, and a storage case storing the substrate and the lens array.
19. The display device of claim 1, wherein the recessed portion is a contact hole for connecting the reflective electrode or the first electrode to the transistor and used as a light emitting area.
20. The display device of claim 10, wherein the transistor is connected to the first reflective electrode provided on at least one of the first recessed portion and the second recessed portion.

专利名称(译)	显示装置		
公开(公告)号	<a href="#">US20200044002A1</a>	公开(公告)日	2020-02-06
申请号	US16/522025	申请日	2019-07-25
[标]申请(专利权)人(译)	乐金显示有限公司		
申请(专利权)人(译)	LG DISPLAY CO., LTD.		
当前申请(专利权)人(译)	LG DISPLAY CO., LTD.		
[标]发明人	JUN CHANGHWA		
发明人	JUN, CHANGHWA		
IPC分类号	H01L27/32 H01L51/52		
CPC分类号	H01L51/5271 H01L27/3246 H01L2251/5315 H01L27/3258 H01L51/5218 H01L27/1248 H01L27/3262 H01L51/5203 H01L51/5237 H01L27/3248 H01L51/5209		
优先权	1020180088955 2018-07-31 KR		
外部链接	<a href="#">Espacenet</a> <a href="#">USPTO</a>		

摘要(译)

显示装置包括：基板，其具有多个子像素区域；电路元件层，其设置在基板上，并且每个子像素区域均具有晶体管；绝缘层，其设置在电路元件层上，并且具有形成重叠的凹部。晶体管，设置在绝缘层上并设置在凹部中的反射电极，设置在与凹部重叠的同时设置在反射电极上的第一电极，设置在第一电极上的有机发光层，设置在第二电极之间的隔堤子像素区域，同时覆盖第一电极的端部以及设置在有机发光层上的第二电极，其中凹部，反射电极和第一电极可以设置N阶，其中N是大于1的整数，从而可以提高光效率。

